

ETA ePE-K
100 to 130 kW

ETA ^η
... my heating system



The powerful pellet boiler for companies
and residential construction



A passion for perfection.
www.eta.co.at



The ETA PE-K is ideal for large apartment blocks, residential buildings, commercial operations and for small local heating networks.

Ideal for new builds and renovations

The heating requirements in large apartment blocks and industrial buildings are often very high, and so are the ongoing costs for heating and hot water - especially if you still use fossil fuels. The conversion is worth it – especially when it's as easy as with ETA. Already during the development of the ETA PE-K pellets boiler, the quality company from Upper Austria had not just in new builds, but especially renovations in its sights. So in most cases no large conversion is required for boiler replacements and existing conditions can be used best. For example, a pellet store can be placed up to 20 metres away – for instance there where the oil tank used to stand.

Serial quality

Larger heating requirements are also no problem for the ETA PE-K. So two, three or even more boilers can be set-up in parallel. This modular or cascade design was perfected by ETA, so that it's not only possible to easily put them into existing properties, but the effort as regards piping, buffer volume, pumps and assembly is also reduced to a minimum.

Everything under control everywhere

The heart of the efficient heating system is the control system, into which even a solar heating system or a small local heating network can be integrated. The boiler features active monitoring of all functions and remote maintenance via GSM and internet, making it ideal for contracting use.

Active control for dependability

Safe operation is ensured by the comprehensive measurement and reporting of the most varied of boiler data, such as the draught fan speed, power consumption of screw motors, air flap position, residual oxygen in flue gas, return riser, exhaust temperature or hot water temperature.

A win-win situation

Save on heating costs, strengthen your domestic economy and look after the environment in the process: heating with pellets is worth it. A drastic price rise is also not expected in the future, as wood always regrows. Currently, around 7 million cubic meters of excess wood is growing in Austria - and forested areas are increasing across the whole of Europe.

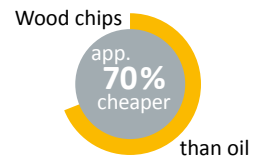
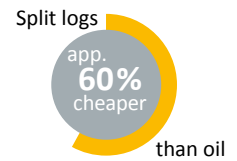
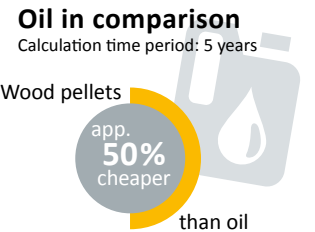
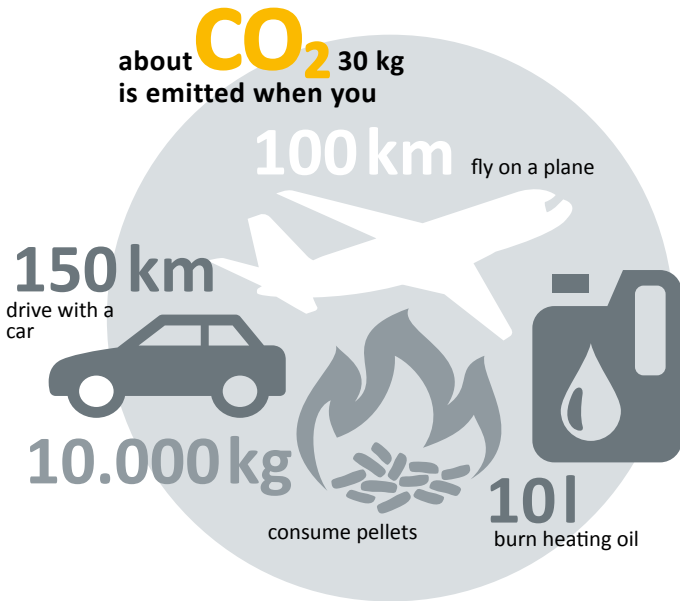
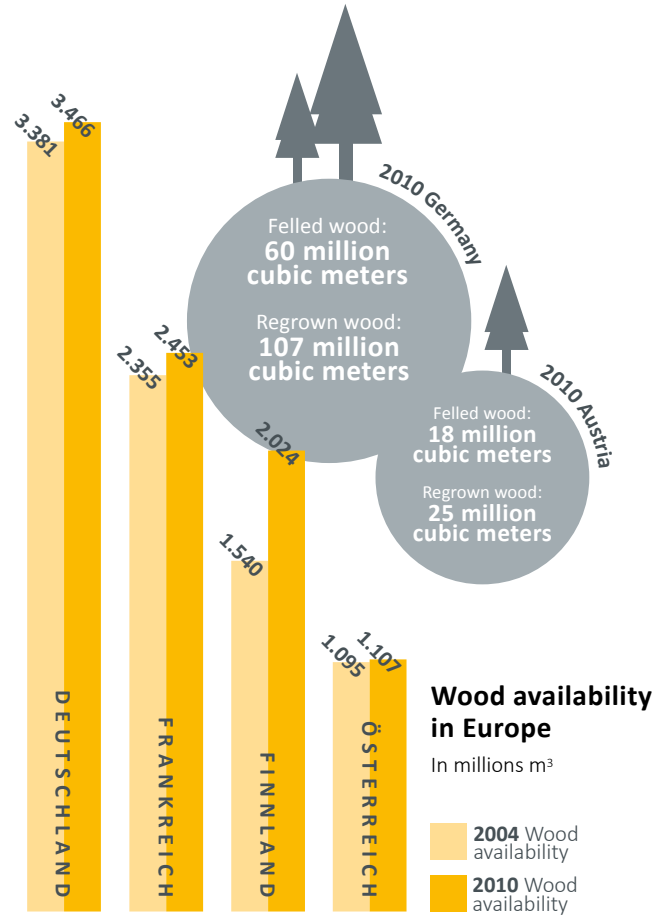

While the price of fossil fuels such as oil and gas is subject to heavy fluctuations in the international markets and will certainly rise long-term, the price of wood and pellets is reliable.

Fuel costs: oil and wood pellets in comparison
2 tons of pellets corresponds to approximately 1,000 liters of heating oil

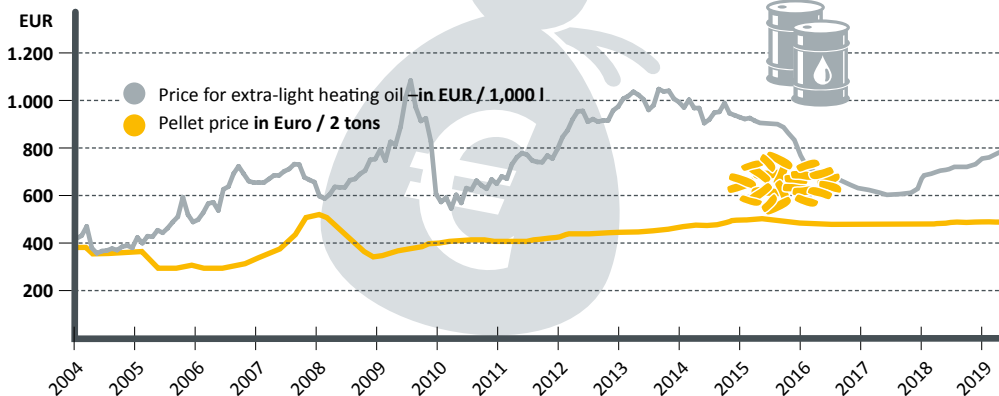

Always space for pellets

The pellet store can easily be set up anywhere where an oil tank stood before. It doesn't even have to be near the boiler, but can be situated up to 20 m and two storeys away. If there's no space in the house, the store room can also be set-up in an adjacent building, or an underground tank can be used. The store room just needs to be dry so that the pellets don't swell up. Wooden cladding can help in rather damp rooms.

A clean solution

The wood pellets, which are pressed from the waste products of the wood industry, are delivered by tanker and blown into the store room. So the delivery of pellets is an extremely clean process. If the store is sealed then no dust can escape here either.

How big does my store room have to be?

The approximate pellet requirement per year in tonnes is calculated by dividing the heating load in kilowatts by 3. For the pellet requirement in cubic metres, simply divide the heating load by 2.

How do the pellets get to the boiler?

Discharge screw:

It stretches the entire length of the store room, can be up to 5 m long and transports the pellets from the store room to the transport hoses, which lead to the boiler. From here, the pellets are conveyed further with a vacuum motor. After transport the hoses are vacuumed empty. Hence they do not clog up and always work with the highest degree of efficiency. With this standard system, the store room can be completely emptied.



So, for example, for 90 kW heating load you need approx. 30 tonnes or 45 m³ of pellets per year.

When moving from another energy source to pellets, the pellet requirement can also be determined from the previous consumption. 1 tonne of pellets roughly corresponds to:

- 500 l heating oil
- 520 m³ natural gas
- 750 l LPG
- 600 kg coal
- 1,400 kWh power with geothermal heat energy pumps (in normal operation 3.4)
- 2,700 kWh power with air heat pumps (in normal operation 1.8)

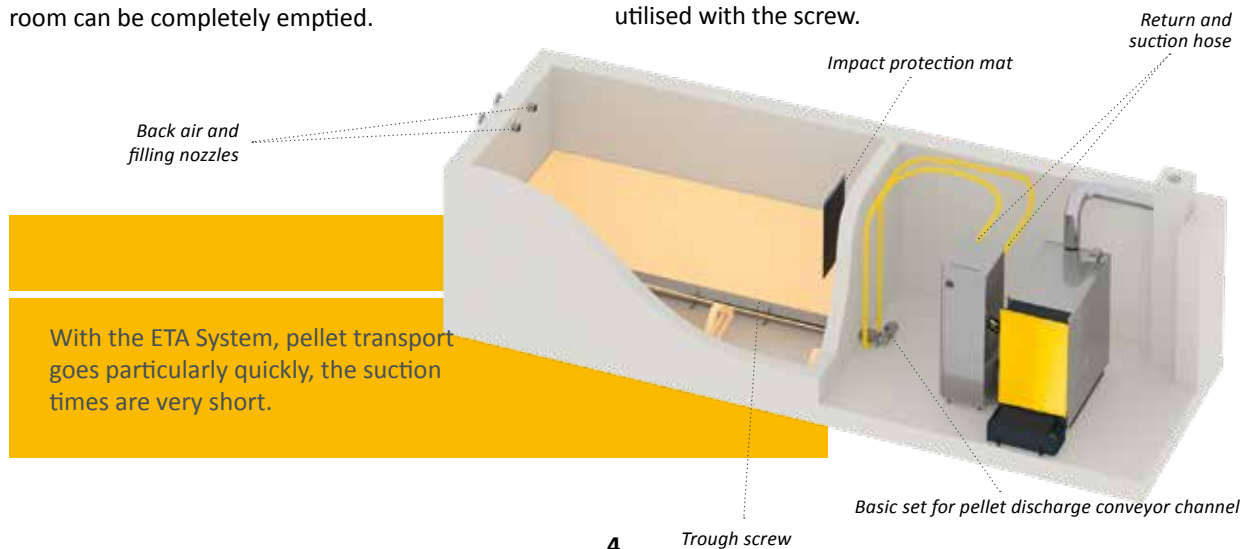

With the ETA System, pellet transport goes particularly quickly, the suction times are very short.

Suction probes:

If the shape of the room is not suitable for a discharge screw, the ETA suction probe system is the ideal choice. Here, the pellets slide over the slanting and smooth wooden floor directly to the four suction probes, which alternately transport pellets away from the store room. Through automatic changeover, the fuel supply is not interrupted if a probe doesn't get any pellets at a certain point in time. The prerequisite for this system is that the

store room is situated opposite the boiler in the same storey or higher, and that the store room is no longer than 4 m. Unlike screws, the suction probes do not fully empty the store room. When the storage room capacity is tight, this can be a disadvantage. The advantage is that this system can be used even in angled store rooms.

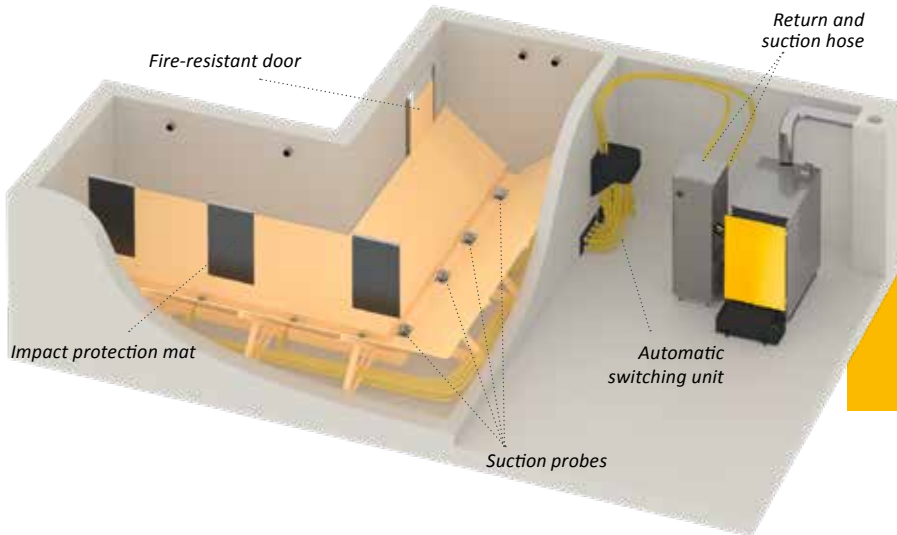

With the suction probes, nearly all rooms can be used as a pellet store, even if it's angular. Eight probes are also possible with larger store rooms.

Mole conveying system:

Due to the structural constraints, conventional ETA pellet conveying systems may have some limitations in terms of usable pellet storage volume. The high quality E3 mole conveying system is a useful application in this situation.

ETA tip: storage in the ETA Box

One particularly practical solution is the ETAbox. It can be set up in the boiler room, in an attic, in a barn or – if covered – even outside. It even keeps the pellets dry in damp rooms. Distances of up to 20 metres of suction hose stretching from the box to the boiler are no problem. Please note that the ETAbox cannot be set up directly on a wall. This is why the space required is a bit larger compared to a brick store with the same capacity.

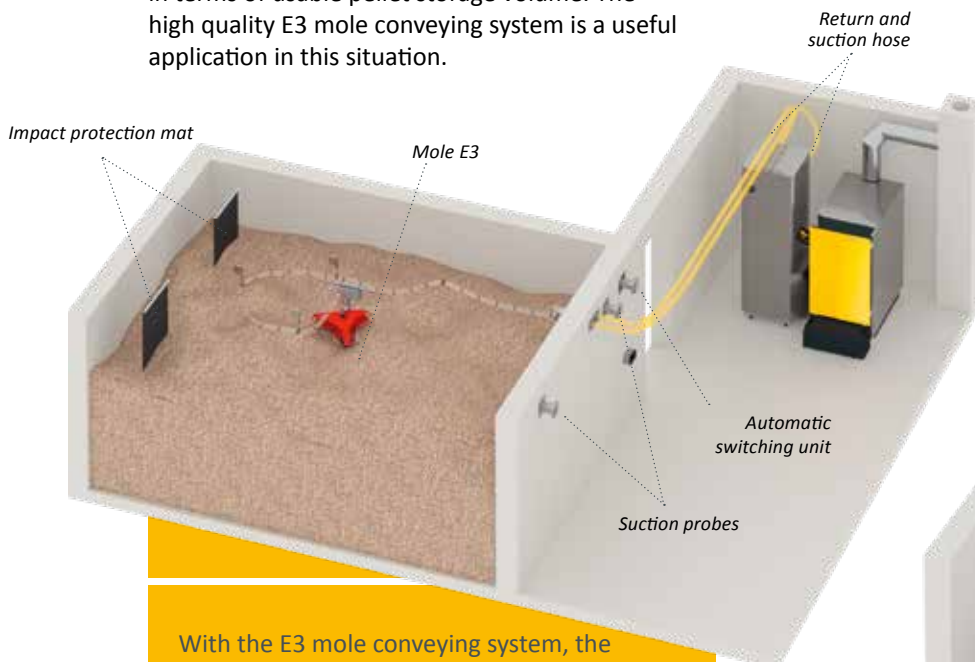

With the E3 mole conveying system, the storage space can be almost completely emptied and the sloping wooden structure is eliminated.

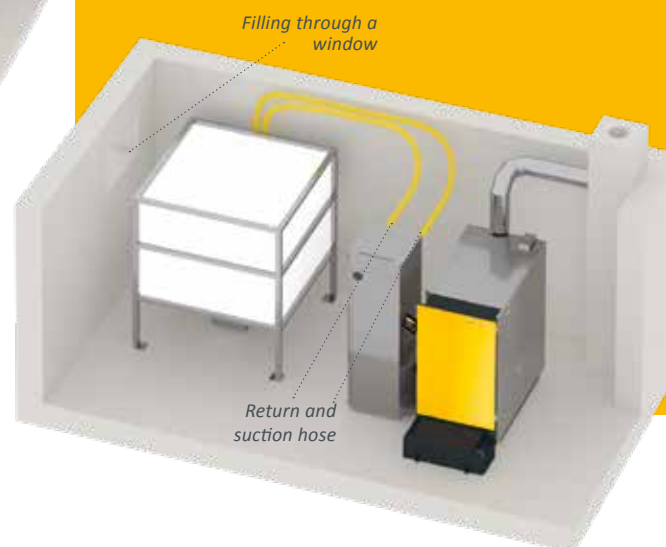

Heat, just the way you need it

The ETA PE-K doesn't just produce heat, the ETA System also distributes it efficiently. Rely on the perfect control centre for your heating and hot water system.

The ETA PE-K is equipped with a control system for the entire heating system. Whether you want to integrate a solar heating system, a conventional hot water preparation system or a buffer storage tank with fresh water module, whether the energy is transferred with radiators or via underfloor heating: You've got everything under control via a touchscreen on the boiler or also via computer or smartphone. Simple images show you if your solar heating system was successful or how full your buffer is.

With buffer, please

ETA buffer storage tank is a perfect partner. Above all, when heating in fall or in spring and for hot water preparation in the summer, often less energy is needed than what the heating boiler produces. The buffer stores this excess heat and releases it on

demand. This saves fuel and protects the boiler, because fewer boiler starts are needed.

The ETA stratified buffer is ideal for the integration of a solar heating system. In summer, hot water can be produced at virtually no operating costs. But in winter, the solar collectors seldom produce the 60 °C that are common for hot water preparation. Then the water that is heated by solar energy is fed through the underfloor heating. This usually works with hot water temperatures of just 30 to 40 °C.

The ETA stratified buffer can also be equipped with a fresh water module, which constantly reheats the tap water with the help of a heat exchanger. Thus the risk of germs and bacteria is minimised.

Remote controlled via the meinETA communication platform.



The ETA mixing circuit module for two heating circuits saves a lot of time and money during installation, as no sensor lines, pumps and mixer cables have to be installed.

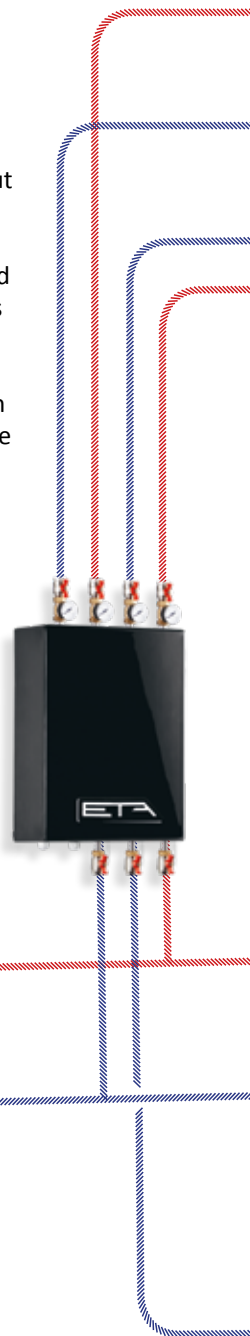

No matter whether solar heating system, hot water preparation or buffer storage with fresh water module: the whole system can be easily controlled from the boiler display.

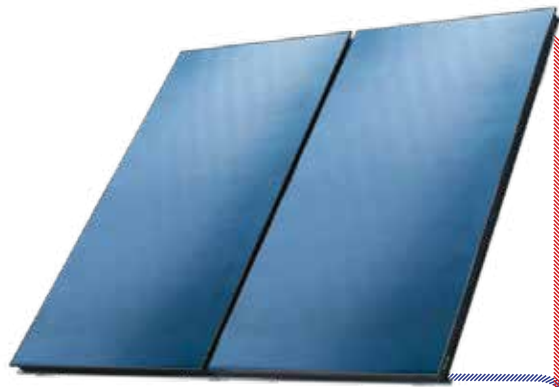

For smaller solar heating systems with large buffer storage tank volumes or for very large solar heating systems, the ETA stratified charging module ensures maximum efficiency.

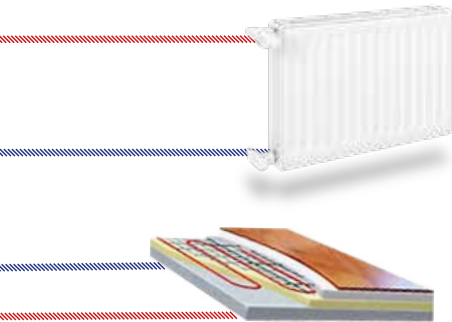

Forget about your boiler
It'll let you know when it needs you! When it's time to add fuel a green signal lamp lights up on the room temperature sensor. Of course you can also set the room temperature on this compact, simple to use device.

The ETA stratified buffer can also be equipped with a fresh water module, which constantly reheats the tap water with the help of a heat exchanger. Thus the risk of germs and bacteria is minimised.

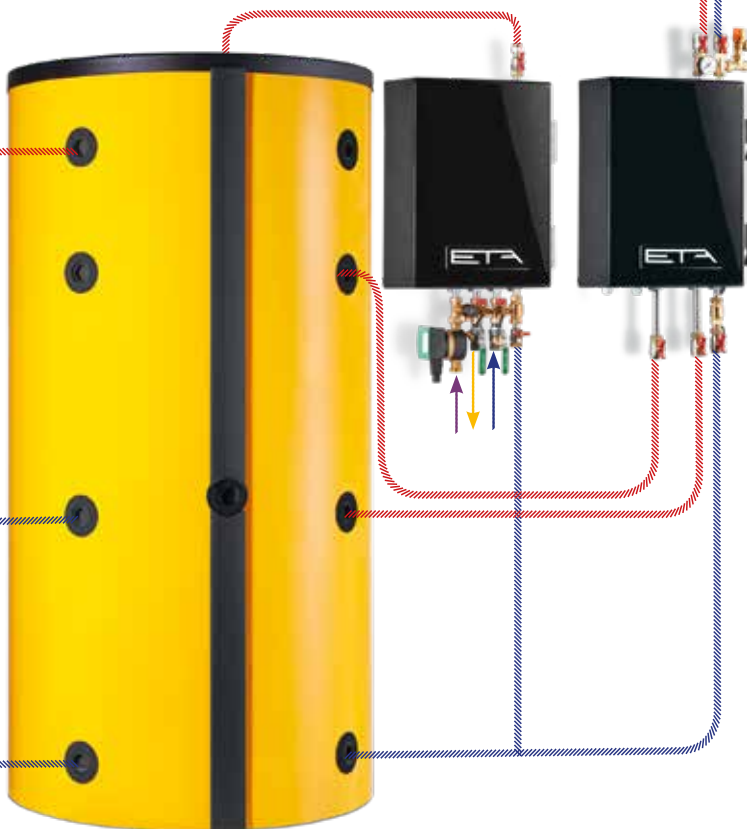

An ETA stratified buffer is the ideal addition to ePE-K. It stores energy that is not required and delivers on demand.



Cleanliness yields the highest efficiency

In ETA systems, the combustion chamber and heat exchanger are automatically cleaned as a whole. This increases the efficiency and minimises the maintenance effort for the boiler.

Eventually the ash box must be emptied – thanks to ash compression and large volume of the ash box less frequently than with conventional systems.

Automatic de-ashing: conclusively progressive

As the screw for de-ashing is about the same size as the stoker screw, foreign bodies such as stones or nails in the ash are no problem either. The screw can also easily be taken out from the front.

Heat exchanger cleaning: permanently high efficiency. A special dampened mechanism cleans the heat exchanger pipes and allows fly ash to fall down with a return movement. Even the optionally integrated precipitator uses this mechanism for its cleaning. That is clean and efficient! The falling ash is largely picked up from the boiler floor via a mini moving floor and fed to a screw placed in the centre.

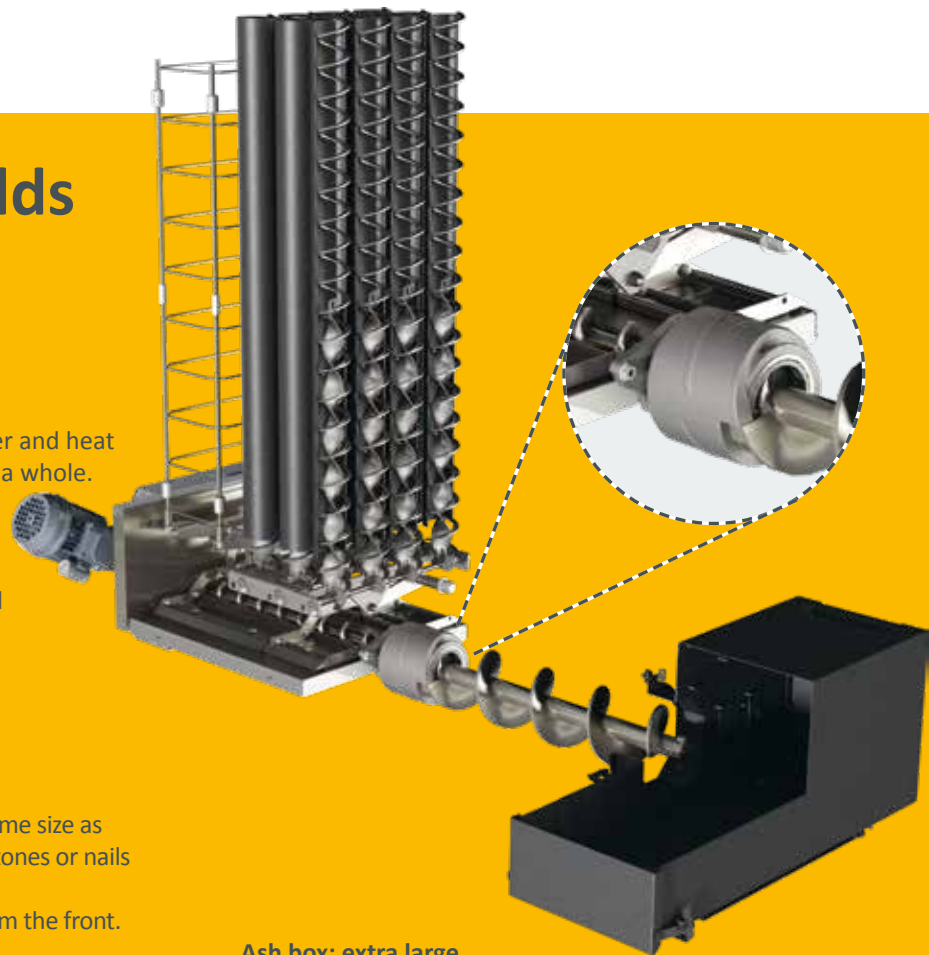

Ash box: extra large, but practical to empty. Ash is conveyed fully automatically into an external ash box. The de-ashing screw compresses the ash and extends the emptying interval significantly in comparison with other systems. The box is best transported with a handcart. A guide plate on the box ensures correct transport, even if it's uneven at times. For simplified discharge, the front cover with the robust lock can be completely removed. So when emptying, the box fits virtually all bins or containers.

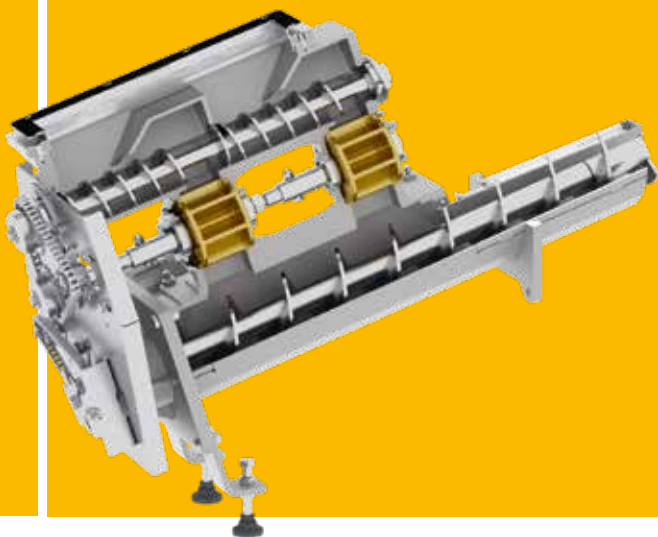

Rotary valve

The safe system. The rotary valve absolutely protects you from burn-back: Burning should only take place in the combustion chamber and nowhere else. A transport screw brings the pellets to the rotary valve – and only as many as the rotary valve can handle. This is why the pellets do not become wedged, crushed or broken. Thanks to this system developed by ETA, the sealed edges of the rotary valve do not wear out. The system remains safe throughout the entire service life of the boiler.



Intelligent technology in the combustion chamber

Optimal fuel utilization. The fuel is pushed from the side to the segment rotating grate in the combustion chamber and subjected to controlled burning there. The refractory-lined combustion chamber with controlled air flow enables a high combustion temperature and thus optimal fuel utilization. Once the material is completely burnt out, the segment grate turns a full 360°. Foreign bodies such as nails and stone safely fall through onto the ash screw which lies beneath. Through the patented rake above the combustion chamber, now the secondary combustion chamber is also de-ashed completely automatically, which increases the efficiency of the boiler and ensures lower flue gas temperatures at the same time.

Overflow protection. This is an important safety measure that ensures that no more fuel is in the chamber that could be combusted. Even if the boiler is cold or wet after a prolonged standstill, or a difficult-to-ignite fuel is used, overfilling of the boiler cannot happen, and thus deflagration is prevented. The sensor-controlled firebed control system always ensures the correct fuel quantity. This is an advantage for alternative fuels such as pellets, but also for very dry wood chips.



Optimised ignition saves energy. With short combustion breaks, the refractory-lined combustion chamber still remains hot enough that any new fuel which is fed in can be ignited by remaining embers. The noiseless ignition is only used after prolonged boiler standstills. The ignition fan is deactivated as soon as the lambda probe and exhaust temperature sensor signal that ignition was successful. That saves energy!



Safely with negative pressure

EC draught fan. Quiet as a whisper, this speed-controlled fan ensures constant underpressure in the boiler. It works very economically thanks to EC motor technology. Additionally, the draught fan ensures oxygen supply in the combustion chamber and therefore for ideal burning behaviour and best utilisation of the fuel. Through the sophisticated boiler construction, the draught fan produces sufficient underpressure in the boiler, so that, contrary to conventional systems, no additional pressure fan is needed. The underpressure sensor provides for even more efficient control of the draught fan. This measures the negative pressure in the boiler and optimises the air supply in the combustion chamber. This minimises operating costs!

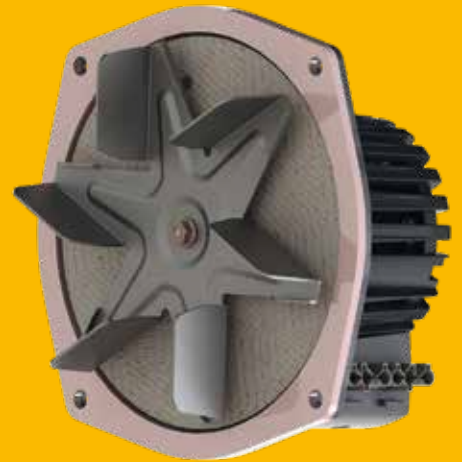

Lambda probe

It's all about the mix. With help of the lambda probe, the mixing ratio of fuel and oxygen is perfectly coordinated, so different fuel qualities always achieve the best possible efficiency. In addition, the probe immediately detects if the ignition was successful. This reduces the ignition time and saves power and money.



The lambda probe is an important part of the combustion technology. In conjunction with the ETA combustion control system, it determines the course and quality of combustion.



7" touchscreen

A capacitive 16:9 format touchscreen with a robust and non-sensitive glass panel now also reacts without pressure making it's operation easier. The display can also be tilted for easier viewing.



Integrated return riser

This ensures quick, space- and cost-saving assembly, as all components are checked and cabled at the factory. A pressure sensor to monitor the water pressure is already installed and an additional connection enables an optimum connection of the safety group.

Pellet hopper directly on the boiler

The pellet hopper with a capacity of 220 kg is sized to operate at full output for at least approx. 8 hours without having to suck in pellets during this time.

The required negative pressure for suction of the pellets is ensured by a vacuum turbine for industrial applications.

With a brushless EC motor, it is extremely low wear and reliable in operation.

The pellets are sucked up by high-quality reinforced hoses, which also have an increased suction volume despite the standard diameter of 50 mm.



Optional precipitator

Clever use of a natural phenomenon

Why does dust keep building up on the computer screen? It's because the dust particles are electrostatically charged and are attracted by the screen – ETA makes use of this effect in its precipitator. With the aid of an electrode in the flue gas duct the particles which are swirling in the flue gas are energised and ionised. This results in the particles being deposited on the internal wall of the separator and no longer escaping from the chimney with the flue gases.

The precipitator is cleaned completely automatically during de-ashing. The dust then lands in the front ash box along with the remaining ash from the boiler.

As the precipitator can be integrated into the eHack, nothing stands in the way of a retrofit and no additional space has to be planned in the boiler room.

With a degree of separation of 80-85%, even for poor fuel the precipitator ensures low dust emission at minimum power consumption.



External de-ashing systems

To achieve even larger de-ashing intervals, ETA offers a de-ashing extension in external containers. The extension can be placed to the left or right of, as well as in front of or next to the boiler! Not only does this

system offer planning flexibility, it also saves a lot of space thanks to the specially designed coreless screw system.

Ash bins with 240 l or 320 l capacity

240 litres

The hot-galvanized steel container has wheels for easier removal, meets the requirements of EN 840, and is suitable for removal by a disposal company.



240 Liter

320 litres

The flap located in the bottom of the container provides a convenient discharge. Using a pallet fork, the container can be transported with front loader or forklift.

The bottom flap is unlocked when the container is either on the wheels or is secured by suitable means. After unlocking, the container can be moved slowly upwards to gently open the flap and minimize the formation of dust.



320 Liter



The way to heat

From the pellet hopper through to the combustion chamber and to the heat distribution system: the interplay of high-quality components is in demand!

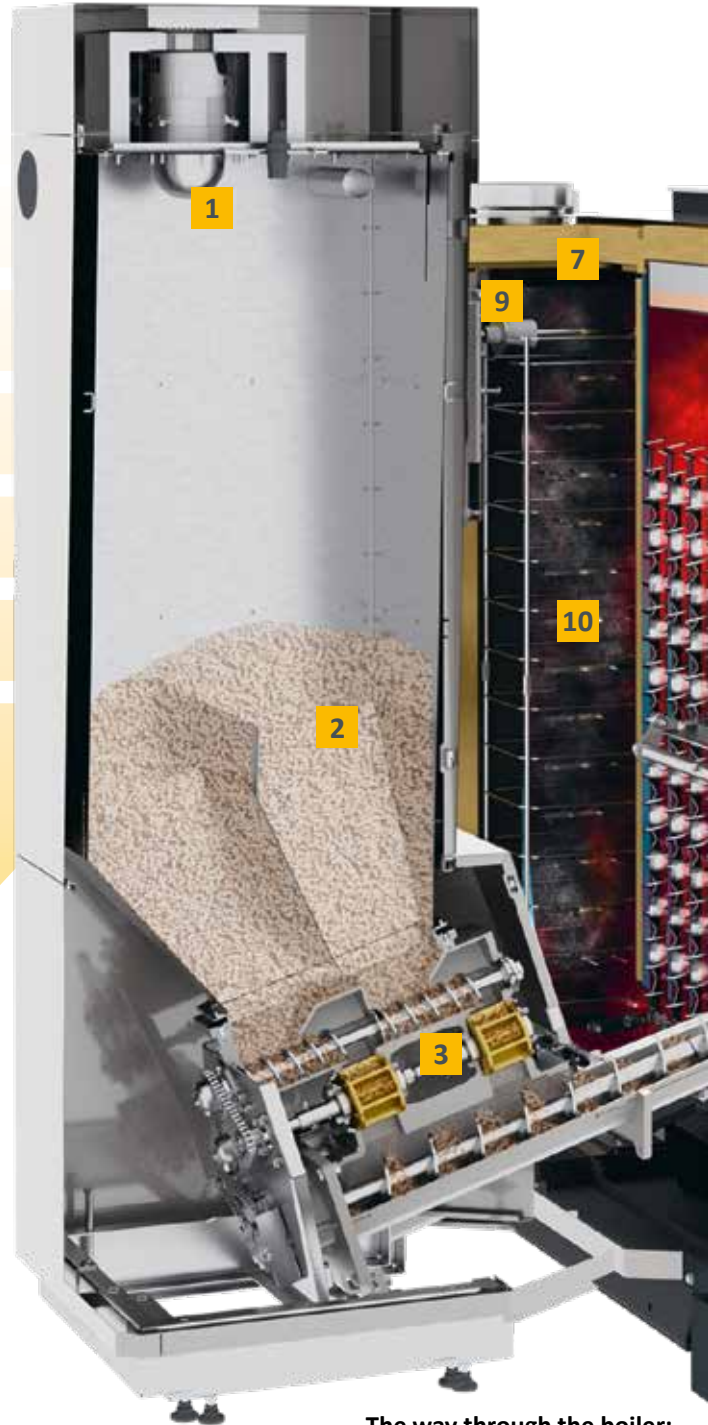
- 1 Vacuum turbine:** It transports the pellets from the store room to the intermediate container of the boiler.
- 2 Pellet hopper:** The pellets are stored here temporarily and are immediately available for combustion.
- 3 Rotary valve as burn-back protection device:** It is the completely sealed closing door between store and ignition and therefore safely protects against burn-back.
- 4 Clean combustion chamber:** To fully free the combustion chamber of ash, the grate automatically tilts at an angle of over 90°, the ash can fall down smoothly.
- 5 Primary and secondary air flap:** Both flaps are controlled via the lambda probe so that the ideal amount of air reaches the combustion chamber for the combustion. The automatic signal calibration ensures that the current data is always processed from the lambda probe and thus that the highest efficiency is continuously achieved.
- 6 Fully automated de-ashing:** Via two separated screws but one common drive, the ash is transported out of the heat exchanger and the combustion chamber to the ash box and compressed there so that the ash box has to be emptied less frequently than with conventional systems.



The way through the boiler:

Fuel	
Flue gases	
Heating water	
Air	

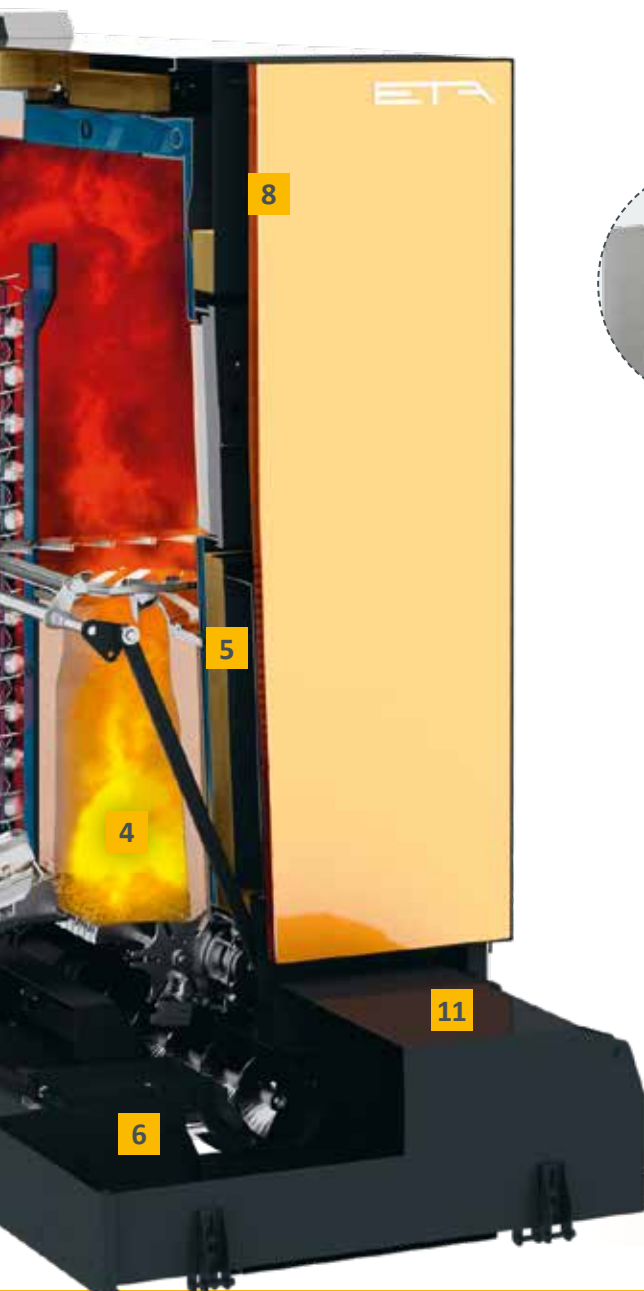

7 Draught fan: Quiet as a whisper, this fan ensures underpressure in the boiler and therefore safety in the boiler room.

8 Touch control system with microprocessors: With just a few swipes of your finger you intuitively control the whole menu. If your boiler is connected to the internet, it tells you by email when the ash box has to be emptied, for example. Furthermore, you can use the free communication platform meinETA with partner network as well as free software updates via USB connection.

9 Lambda probe: Helps for the mixing ratio of fuel and oxygen to be perfectly regulated. So different pellet qualities always achieve the best possible efficiency.

10 Heat exchanger cleaning: The heat exchanger is fully automatically cleaned with turbulators. This ensures constantly high efficiency.

11 Insulating door: As you don't have to heat the boiler room but instead the house, the insulated outer door protects against heat losses by radiation.

12 External ash box: The ash is compressed so that the ash box has to be emptied less often than with conventional systems. It can be accessed easily and comfortably.



Away mode, night time reduction, vacation setting: intuitively, you know immediately which button does what.

Easy to control from anywhere

Good technology is characterised by its user friendliness. You don't have to be a technician to use the many functions of the ETAtouch.



You can control the boiler via smartphone, PC or tablet as well as directly on the touchscreen.

ETAtouch: the touchscreen on the boiler

Confusingly arranged buttons and control systems are a thing of the past, because with the touchscreen of the ETA PE-K you can quickly and easily control all settings. The icons are self-explanatory. Whether you generally want to make it warmer or cooler, change the time for night-time reduction or want to switch to eco mode during your vacation - you will tap on the right symbol intuitively and completely without operating manuals!

You not only control your boiler via the touchscreen, but also have an overview of all connected components, such as buffer storage tank, pellet store, solar heating system or hot water preparation. You know straightaway, for example, how many pellets you still have in store or how effective your solar heating system was.

meinETA: the free internet platform

If your heating boiler is connected to the internet,

you can see and change all heating settings on your mobile, tablet or PC. So you always have a handle on your heating, wherever you are! When you login to www.meinETA.at, you see the touchscreen as if you were standing right in front of the boiler!

The pellet store needs filling, the ash bin must be emptied, it's time for the next heating service... You don't have to remember all these things yourself. meinETA reminds you for free by email.

Quick help

Give your installer or the ETA customer service representative temporary access rights to your meinETA account. So they can prepare for their visit to you. And maybe the technician doesn't even have to come visit, because thanks to meinETA they can tell you over the phone what you need to do to make your heater work again. You can see who can access your boiler via the status display. Only you decide who's in your network!



*Come home to a warm house:
the boiler can also be controlled
while you're out and about.*

Technical requirements for meinETA

To be able to use meinETA, you need a broadband connection in your home. The ETA boiler's touch screen is connected to the Internet via a network cable. And anyone who doesn't have a network connection in the basement simply connects via the ETA PowerLine. It comfortably transfers the data from any socket to the modem.

For tablet, smartphone and PC

meinETA runs on all current operating systems, such as iOS or Android. Via PC, meinETA can be loaded by any modern internet browser, such as Mozilla Firefox, Safari, Google Chrome or Internet Explorer 9, for example.

Integration into Building Management

The integration into an on-site building management or master control system is relatively unproblematic. Values can be queried and changed with RESTful web services and Modbus/TCP.



There for you

ETA devices are characterised by the highest quality. They feature patented systems developed in Austria. The entire assembly takes place in-house in Hausruckviertal, Austria. In the unlikely event of a breakdown, ETA customer service is on the spot quickly. An experienced, competent on-call team is available to you.

Everything on one display: the ETA Standard

A modern heating system is only effective if it is well-controlled. ETAtouch takes care of that.

At no added cost, the ETAtouch control system already includes all functions for two heating circuits, hot water supply via tank or instantaneous hot water module, as well as for the integration of a solar heating system. All ETA heating boilers also come with a LAN connection as standard. If you connect the boiler to the internet, you can easily control all components from a PC, tablet or smartphone.

Boiler and combustion regulation*

Speed-controlling the several components save power. The lambda and ignition time regulation increases efficiency. All components relevant to operation are monitored.

Buffer storage tank management**

Three to nine sensors in the tank control the heat generator in the system and distribute the energy to the different consumers. From using five sensors, cascading regulation, QM-Holz and peak load management are part of the ETA Standard.

Hot water preparation*

Is made possible both via the ETA instantaneous hot water module but also via the hot water tank or combination tank. For all variants, circulation pumps can be controlled with time and/or requirement programs.

Solar heating systems**

Single or double circuit solar heating systems with one or two tanks, zone loading via the ETA stratified charging module and also two collector fields as well as three consumers are controlled.

Two weather-controlled mixing heating circuits**

They run with a weekly program which allows many time windows and automatic and/or manual additional functions. The system can optionally be expanded with room sensors and remote control.



Comprehensible also without the need for an operating manual: The symbols on the touchscreen are self-explanatory. So controlling the heating system becomes child's play.

Additional system functions

Detection of third-party heating devices, such as oil boilers, gas boilers, heat pumps and wood burning stoves, thermostat or differential temperature thermostat, external demand from external devices such as heating fans, control of transmission lines, with or without mixers, and also of heat transfer stations, single room control systems, for example.

Wall-mounted control box for more complex systems

All control systems can be extended with wall-mounted control boxes, with or without touchscreen.

*Control system and sensor included in standard delivery scope

**Control system depends on configuration, sensors are available as accessory

From Hausruckviertel to the world

ETA specialises in the manufacture of biomass heating, i.e. log, pellet and wood chip boilers. The most modern technologies combined with naturally growing resources.

ETA is efficient

Technicians designate the efficiency of a heating system with the Greek letter η , pronounced „eta“. ETA boilers stand for more heat with less fuel consumption, environmental soundness and sustainability.

Wood: old but excellent

Wood is our oldest fuel - and our most modern: There is a lot of history - from open fires in front of caves to modern biomass boilers. In the middle of the 20th century, the number of wood heating systems briefly fell. Oil heating became the new, hyped option. A brief interlude in comparison to the consistency of wood. Today, we know that heating with fossil fuel has no future. It contributes to global warming and harms the environment. Supply security is also not guaranteed in the long term, as fossil fuels are being depleted, aren't renewable and often come from unstable regions. While wood by contrast is a cheaper, locally grown, renewable raw material that does not pollute the climate when burnt. No wonder wood heating is booming!

Comfort with many components

Since December 1998, the Upper Austrian company ETA has been designing and building a new generation of wood-fired boilers. They are full of patented technologies and the most modern control technology – making them easy to use. Convenience and efficiency make ETA products so popular around the world. With a production capacity of up to 20,000 boilers per year and a global export proportion of around 80%, ETA is one of the leading biomass boiler producers.

You get more than just a boiler

Anyone who decides on a wood or pellet boiler from ETA is choosing sustainability. This is not just in terms of fuel, but encompasses responsibility across the board, with sustainable workplaces in the region. More than 200 employees in Hofkirchen an der Trattnach have the best working conditions – including an in-house restaurant, bright assembly and storage halls, a fitness room and a sauna. There is even a free electric charging station for electric cars, which is supplied by the in-house photovoltaic system. This also covers all the power needed of a production hall and thus saves around 230 tonnes of CO₂ per year.



Pellet boiler ETA ePE-K 100 - 130 kW

- 1** Connection for safety valve, pressure gauge and bleed valve, R1"
- 2** Flow, R2"
- 3** Return, R2"
- 4** Filling and draining valve
- 5** Safety heat exchanger R1/2"
- 6** Maintenance area to be kept clear

The boiler can optionally be supplied with the pellet module on either the left or the right side.

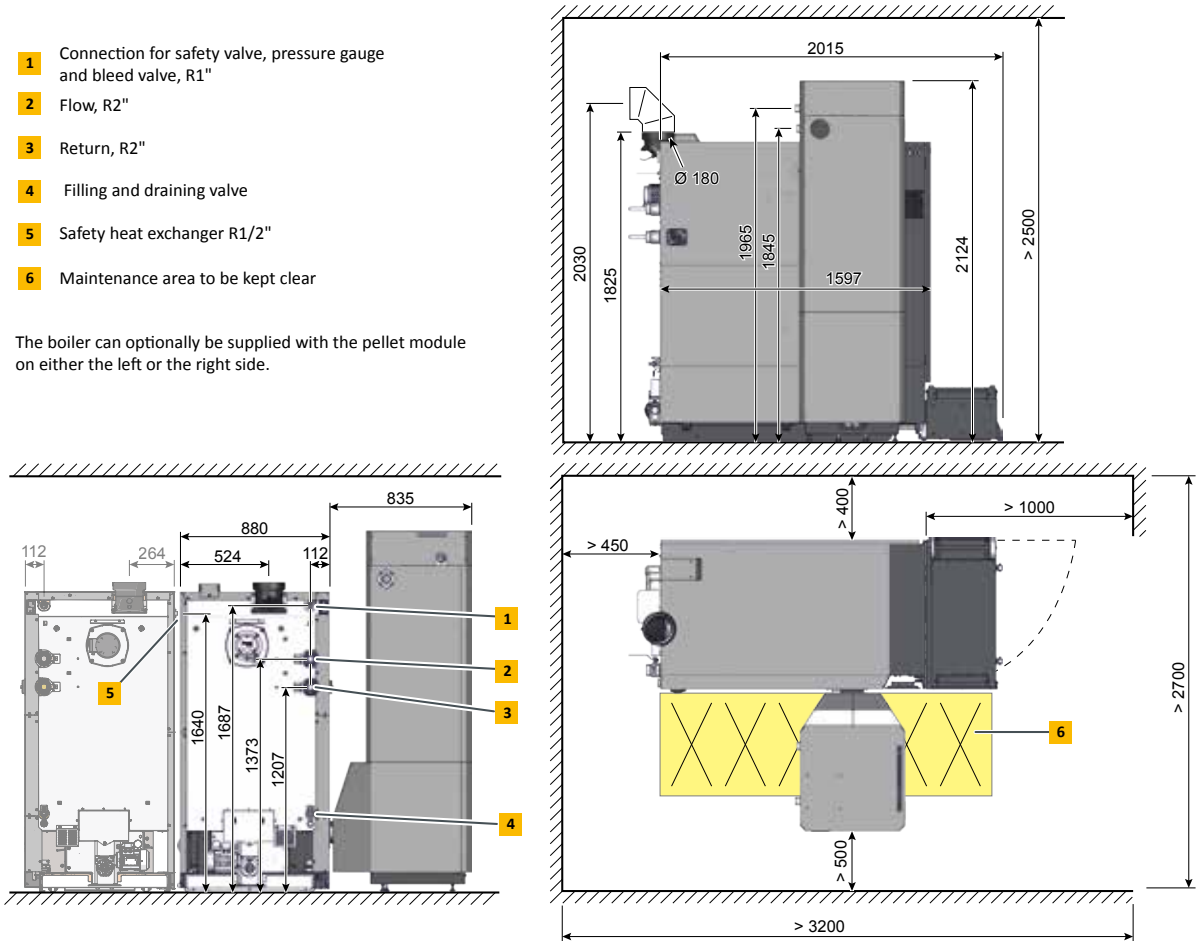



Pellet boiler		100	110	120	130
Rated capacity	kW	29,9-99,9	32,9-109,9	35,9-119,9	38,9-129,9
Efficiency at partial/full load*	%	92,8 / 93,0	92,4 / 93,0	92,0 / 92,9	91,6 / 92,9
Transport dimensions (boiler) W x D x H	mm	922 x 1.764 x 1.825			
Weight of the boiler	kg	1.329			
Weight of the pellet module with stoker	kg	200			
Water content	litres	272			
Water-side pressure drop ($\Delta T=20$ K)	mWs	0,778	0,941	1,121	1,331
Pellet bin on boiler (net)		220 kg (1.078 kWh)			
Maximum distance to pellet store	m	20			
Required flue draught	Pa	>5 A draught limiter is required above 15 Pa			
Electrical power consumption at partial/full load (=values with integrated precipitator)	W	49 / 124 (148 / 211)			
Electrical power consumption in standby*	W	13			
Maximum permissible operating pressure	bar	3			
Temperature adjustment range	°C	70 - 85			
Maximum permissible operating temperature	°C	95			
Minimum return temperature	°C	60			
Boiler class		5 acc. to EN303-5:2012			
Suitable fuels		Pellets ISO 17225-2-A1, ENplus-A1			
Electrical connection		1 x 230 V / 50 Hz / 13 A			

*Data from test reports by BLT Wieselburg

Technical changes and mistakes reserved!



entspricht
EU-Normen



BLT Wieselburg
Österreich



TÜV
Süddeutschland

NOTES

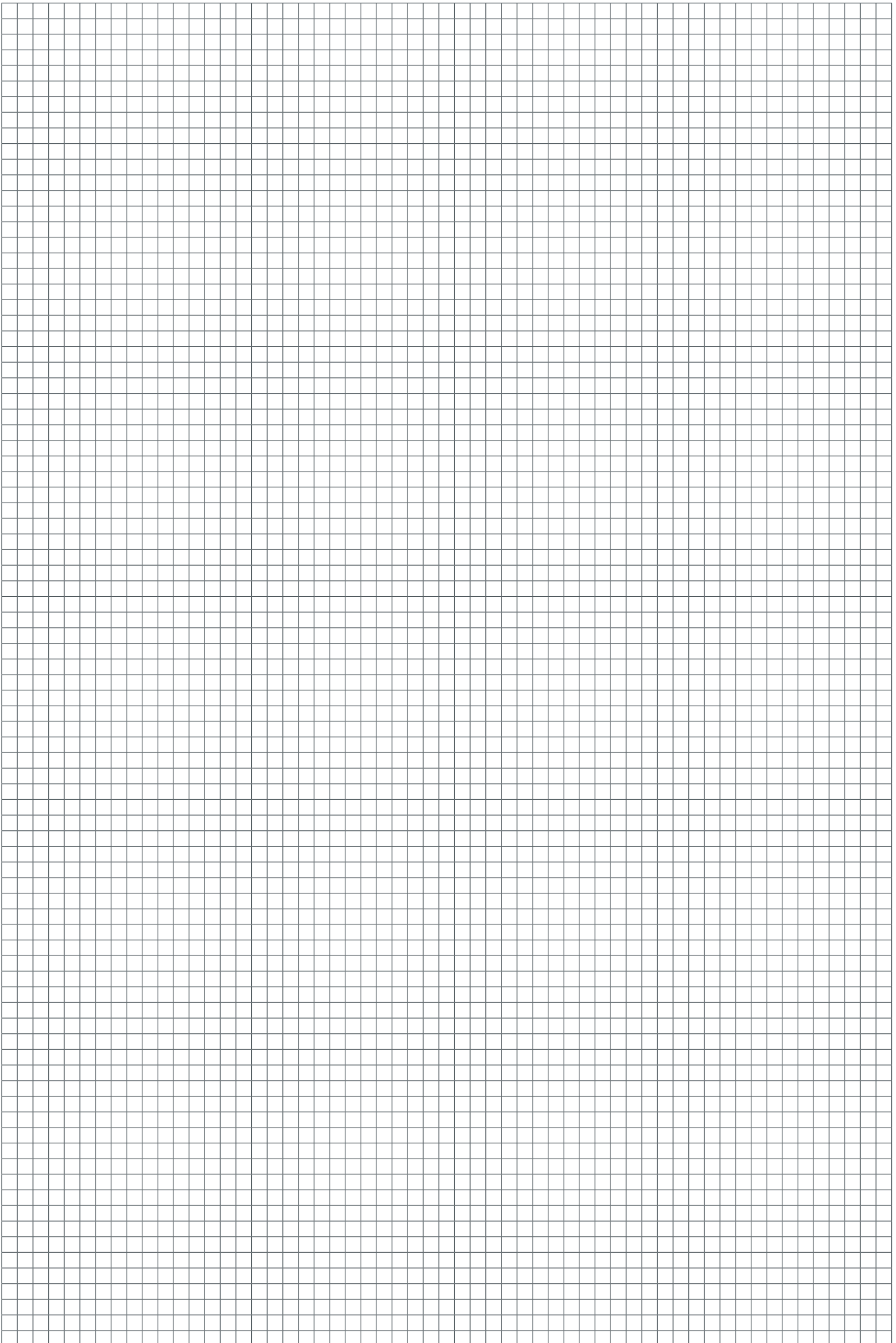

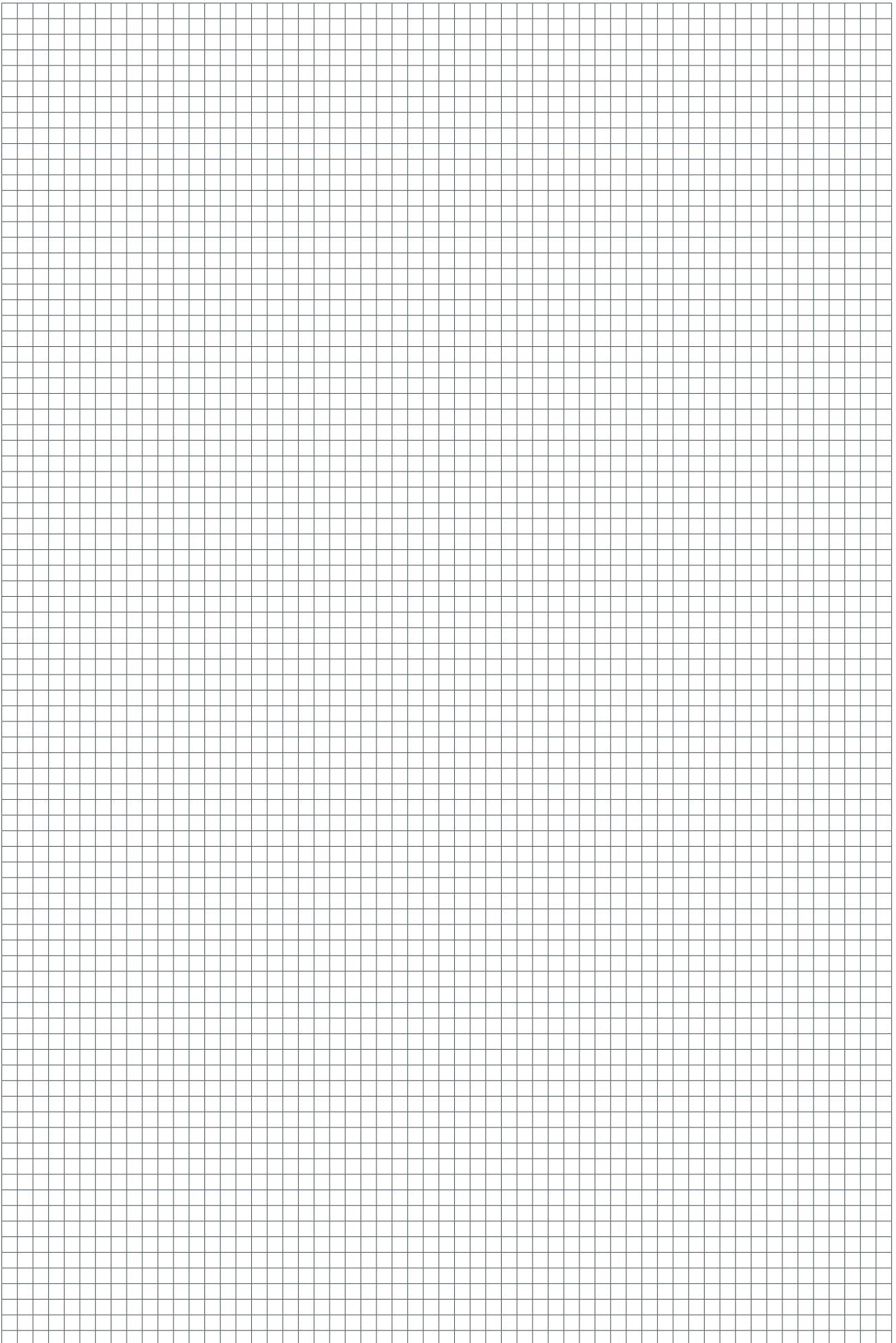



ETA PU PelletsUnit 7 to 15 kW



ETA PC PelletsCompact 20 to 105 kW



ETA ePE-K Pellet Boiler 100 to 130 kW



ETA PE-K Pellet Boiler 180 to 220 kW



ETA SH Wood Gasification Boiler
20 to 60 kW



ETA SH-P Wood Gasification Boiler 20 to 60 kW
with ETA TWIN Pellet Burner 20 to 50 kW



ETA stratified buffer SP 500 to 5,000 lt
and SPS 600 to 2,200 lt



ETA Hydraulic modules



ETA eHACK Wood Chip Boiler
20 to 130 kW



ETA HACK Wood Chip Boiler
200 kW



ETA HACK VR Wood Chip Boiler
with moving grate 250-500 kW

INNASOL
SUPER POWER

Innasol Ltd.
Reigate Barn,
Langford Road
Wickham Bishops, Essex CM8 3JG
Phone: +44 (0) 1621 / 892 613
info@innasol.com
www.innasol.com

Your heating specialist will be happy to advise you

ETA
...mein Heizsystem

ETA Heiztechnik GmbH
Gewerbepark 1
4716 Hofkirchen a. d. Tr., Austria
Tel.: +43 (0)7734 2288-0
Fax: +43 (0)7734 2288-22
info@eta.co.at
www.eta.co.at

Technical changes and mistakes reserved

In order to provide you the benefits of our continuous development, we reserve the right to change specifications without prior notice. Printing and typesetting errors or changes of any kind made in the interim are not cause for claims. Individual configurations depicted or described here are only available as options. In the event of discrepancies between individual documents regarding the scope of delivery, the information provided in our current price list shall prevail. Images and symbols may contain options that are available for an additional cost.

Photo source: ETA Heiztechnik GmbH, Lothar Prokop Photographie, istockphoto, Thinkstockphotos, Photocase, Shutterstock.
94201-EN-INNASOL, Prospekt Pelletskessel ETA PE-K EN, 2019-02

